

## Bronze Fixed Orifice Double Regulating Valve

PN25

Size ½" to 2" only

### Specifications:

IVAL® Bronze 'Y' Pattern Type Fixed Orifice Double Regulating Valve, Conform to BS7350, Handwheel operated, Numerical indicator, inside screw non-rising handwheel, characterized regulating disc, Integral fixed orifice, Supplied with two test points.

The valve body and bonnet made of bronze, disc and stem made of DZR Brass.

**UK END CONNECTION:** BSPT Taper Threaded to BS EN 10226-1, compatible with ISO 7/1.

**WRAS approved**

### Features:

- Provides precise and accurate flow regulation.
- The FODRV offers an accuracy of  $\pm 5\%$  on all settings, for precise flow regulation and measurement.
- The Double Regulating feature allows the valve to be used for isolation and to be reopened to its pre-set position to maintain required flow rate.
- Y-Pattern globe valves having characterized throttling disc tending towards equal percentage performance.
- Single unit Y-pattern valve incorporating fixed orifice plate flow measurement unit, Fitted with a pair of measuring plugs.
- Conforms to BS7350 for flow measurement and regulation.

### Pressure /Temperature Ratings:

Temperature (°C)	-10 to +100	120
Pressure (Bar)	25	21.8

Intermediate pressure ratings shall be determined by interpolation.

### Materials:

No.	Description	Material	Specification
1	Body	Bronze	EN1982 CB491K
2	Venturi Insert	DZR Brass	EN12164 CW602N
3	Test Points	DZR Brass	EN12164 CW602N
4	Test Point Tag	Plastic	-
5	O-Ring	EPDM	-
6	Bonnet	DZR Brass	EN12164 CW602N
7	Disc Assembly	DZR Brass + EPDM	EN12164 CW602N
8	Handwheel	Plastic	PA6 + 30%GF
9	Nut	Stainless Steel	AISI 304
10	Stem	DZR Brass	EN12164 CW602N
11	Packing Nut	Brass	EN12165 CW617N
12	Packing	PTFE	-
13	Washer	PTFE	-
14	Set Screw	Stainless Steel	AISI 304

Suitable for Water. Not suitable for: gases group 1 & 2, liquids group 1 (Dir. 2014/68/UE)

## TECHNICAL DATASHEET

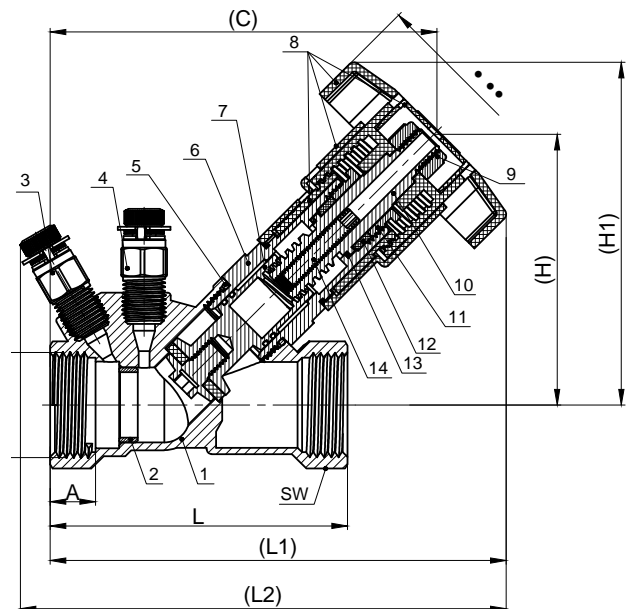

### Dimensions:

Size	L	L1	A	H	H1	L2	Wt.
DN15	72.5	121.2	12.5	74.8	98.1	135.6	563
DN20	82	130.2	12.5	79.2	103.5	140.5	614
DN25	95	137.1	14.5	81.7	106	147.5	725
DN32	115	153.2	16.5	93.7	118.1	140.5	1,097
DN40	135	171.5	19	102.4	126.7	155.3	1,624
DN50	150	182.7	19.5	112.4	136.7	168	2,090

All dimensions in mm and Weight (Wt.) is in grams unless otherwise stated.

### Test Pressures:

Each valve is individually hydrostatically tested at the following test pressure:

**Shell** Testing Pressure (x1.5) = 37.5 Bar

**Seat** Testing Pressure (x1.1) = 27.5 Bar



**Flow Characteristics:**

Tolerance on nominal **Kvs ±5%** (test according to BS7350)

Supplied with red and blue test points for upstream and downstream port identification.

**Kvs** is the signal pressure drop measured across the fixed orifice test points:

Size	Kvs (Venturi)
DN15 - 1/2"	5.36
DN20 - 3/4"	8.60
DN25 - 1"	13.87
DN32 - 1.1/4"	18.63
DN40 - 1.1/2"	24.02
DN50 - 2"	28.56

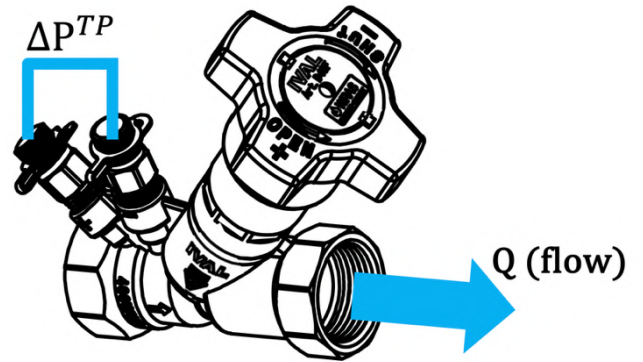

Formula linking flow **Q in (l/s)** and **ΔP in (KPa)** measured at test points:

$$Q = \frac{K_{vs} \cdot \sqrt{\Delta P^{TP}}}{36}$$

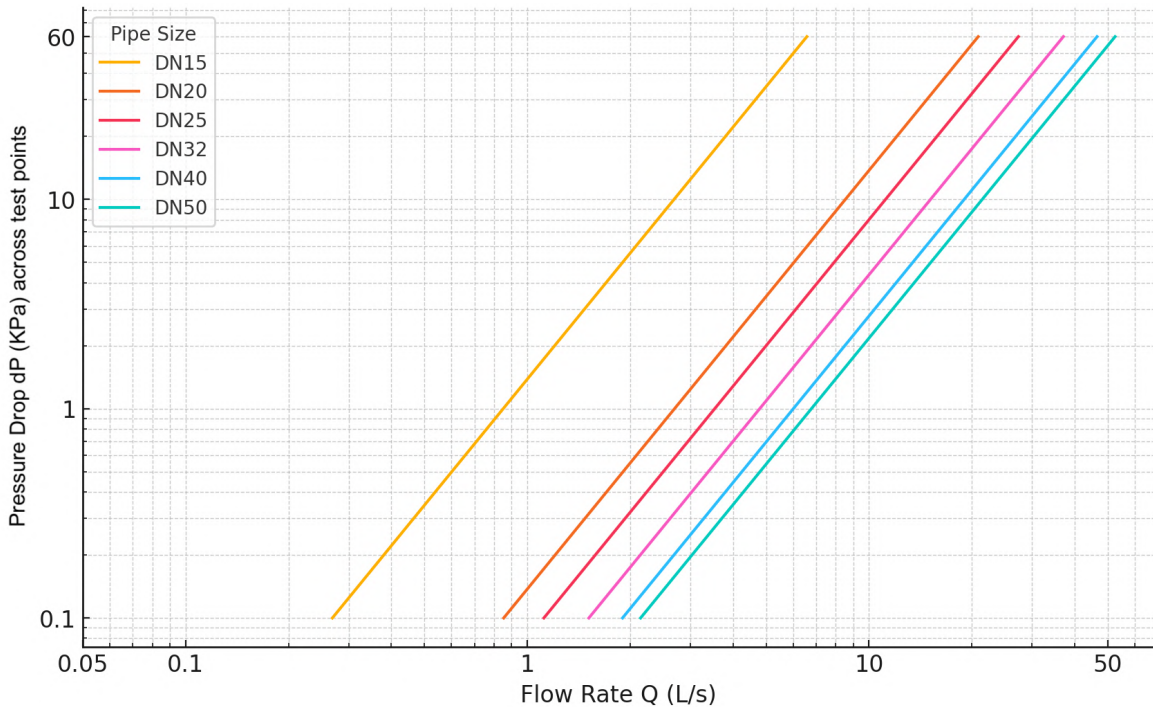

**Headloss Calculations:**

Handwheel Position	Kv [m3/h @ 1bar]					
	DN15	DN20	DN25	DN32	DN40	DN50
0.5	0.51	1.40	1.64	4.11	5.92	4.86
1.0	1.16	2.40	2.85	5.39	9.36	10.11
1.5	1.59	3.22	3.92	7.38	12.36	15.27
2.0	1.89	4.02	5.07	9.23	15.47	19.95
2.5	2.07	4.91	6.12	11.06	18.02	23.84
3.0	2.20	5.64	7.15	13.15	20.33	27.37
3.5	2.28	5.97	8.15	14.46	21.88	30.36
4.0	2.33	6.34	9.02	15.04	23.48	33.16

Formula linking flow **Q in (l/s)** and theoretical valve headloss **ΔP in (KPa)**:

$$\Delta P = \left( \frac{36 \cdot Q}{K_v} \right)^2$$

**Kv** depends on handwheel position as indicated in the table.

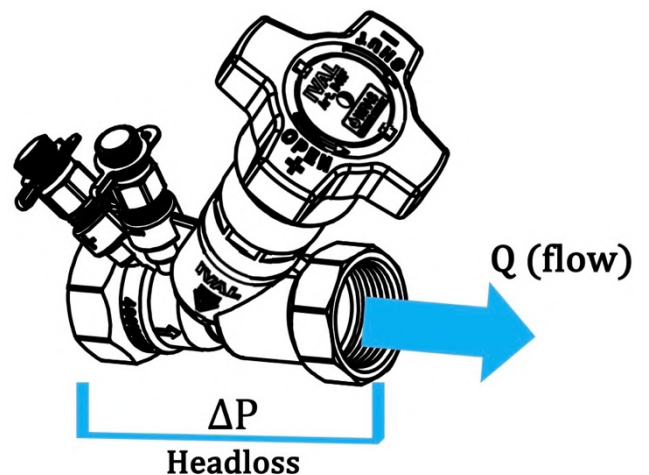

Drawings, photos and data contained in this document are provided for information only. IVAL reserves the right to change them without notice.

