

D70V

Variable Orifice Ductile Iron Double Regulating Valve
PN16
Size 2½" to 16"

Specifications:

IVAL® Variable Orifice Double Regulating Valves are Y-Pattern globe valves suitable for flow regulation and isolation.

Valves are supplied with test points to enable flow measurement.

Valves conform to requirements of BS 7350 and ends are flanged to BS EN 1092-2.

Features:

- Y-Pattern globe valve with a characterised throttling disc.
- The Double Regulating feature allows the valve to be used for isolation and to be reopened to its pre-set position to maintain required flow rate.
- The valve opening may be set to control flow at a pre-determined rate.
- Operation of the valve is by means of a hand wheel incorporating a micrometre device.

Pressure/Temperature Ratings:

Temperature (°C)	-10 to +110
Pressure (Bar)	16

Test Pressures:

Each valve is individually hydrostatically tested at the following test:

(HYDRAULIC) Shell: 24 bar - **Seat:** 17.6 bar

Materials:

No.	Description	Material	Specification
1	Valve Body	Ductile Iron	EN-GJS-450-10
2	Disc	Brass	EN12164 CW614N
3	Disc Screw	Brass	EN12164 CW614N
4	Test Points	Brass	EN12164 CW614N
5	Cover	Ductile Iron	EN-GJS-450-10
6	Gland	Brass	EN12164 CW614N
7	Handwheel	PA GF30, AL	-
8	Stem	Brass	EN12164 CW614N
9	O-Ring	VITON	-
10	Socket Head	Stainless Steel	AISI 304
11	Adjust Screw	Stainless Steel	AISI 304
12	O-Ring	VITON	-
13	Socket Head	Stainless Steel	AISI 304
14	O-Ring	VITON	-
15	Gasket	EPDM	-

Suitable for water: Below 0°C only for water with added antifreeze fluids, over 100°C only for water with added anti-boiling fluids (ethylene glycol or propylene glycol mixtures up to 50% may be used). Not suitable for: gases group 1 & 2, liquids group 1 (Dir. 2014/68/EU)

TECHNICAL DATASHEET

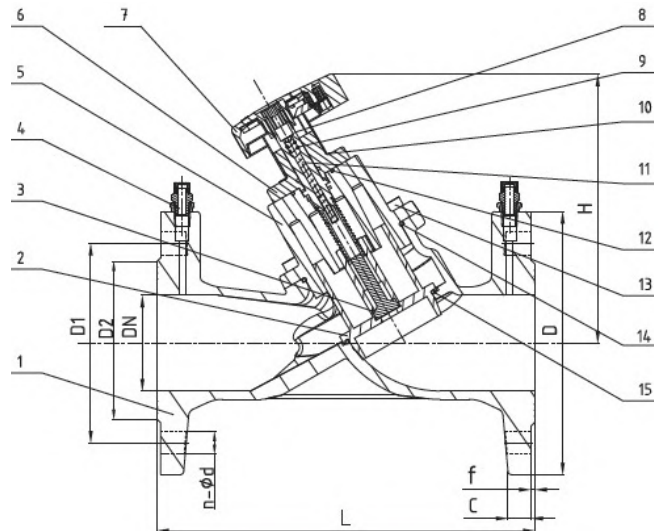

Dimensions:

DN	Dimensions (mm)					No. of Turns	Wt. (Kg)
	Inch	mm	L	H	D		
2.5"	65	290	185	185	4-Ø19	8.0	14.72
3"	80	310	225	200	8-Ø19	7.0	17.39
4"	100	350	240	220	8-Ø19	8.0	24.11
5"	125	400	280	250	8-Ø19	7.0	34.87
6"	150	480	300	285	8-Ø23	8.0	46.67
8"	200	600	450	340	12-Ø23	11.0	92.85
10"	250	730	500	405	12-Ø28	12.0	147.18
12"	300	850	828	460	12-Ø26	16.0	194.85
14"	350	980	970	520	16-Ø26	20.0	347.12
16"	400	1,100	1,100	580	16-Ø30	22.0	472.09



Flow Characteristics:

Formula linking flow **Q (in l/s)** and **ΔP (in kPa)** measured at test points. Kv depends on handwheel position as indicated on table in the next page.

Minimum flow that can be measured for each diameter may be calculated by using in the formula minimum ΔP that can be measured by used manometer.

$$Q = \frac{K_v \cdot \sqrt{\Delta P^{TP}}}{36}$$

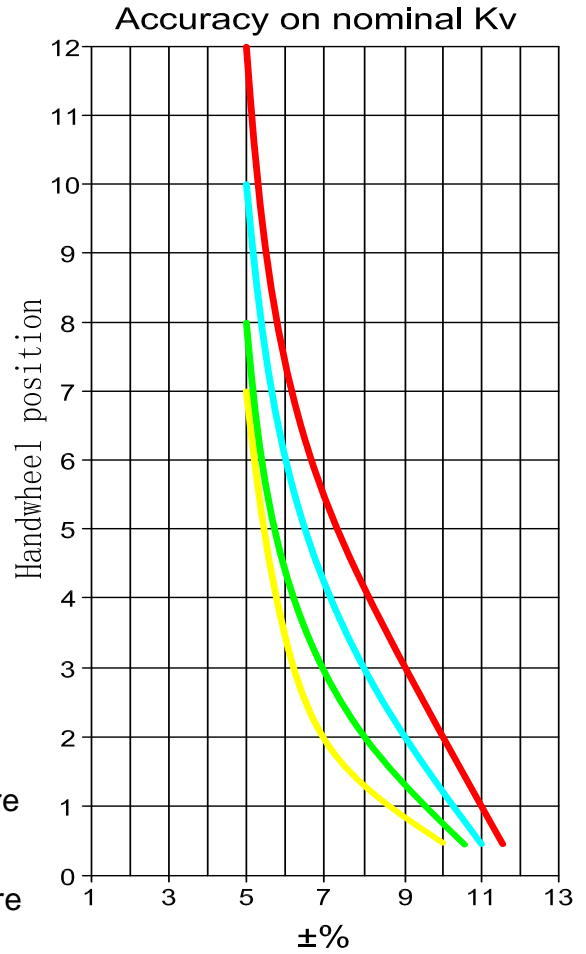
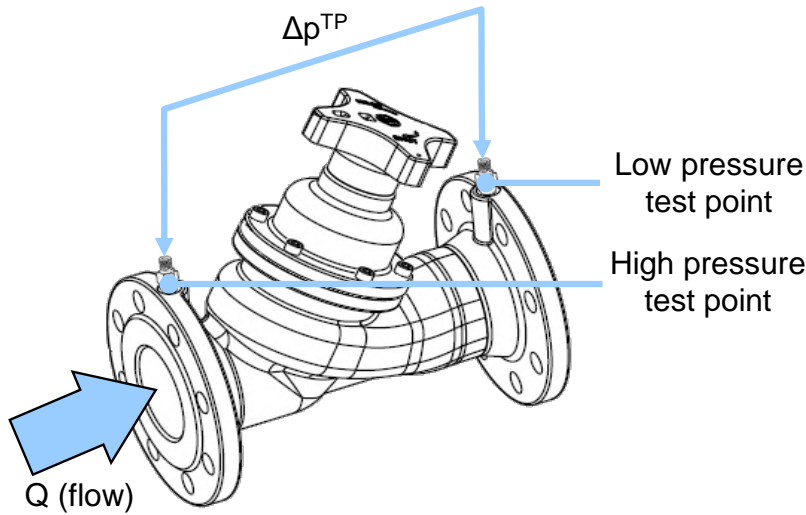

- DN65/125
- DN80/100/150
- DN200
- ≥DN250

Drawings, photos and data contained in this document are provided for information only. IVAL reserves the right to change them without notice.



Turns	Kv (m ³ /h @ 1bar)									
	DN65	DN80	DN100	DN125	DN150	DN200	DN250	DN300	DN350	DN400
0.5	5.25	5.62	6.75	12.53	13.95	16.95	25.56	-	-	-
1.0	6.60	7.10	9.59	18.10	20.92	23.99	38.35	-	-	-
1.5	7.27	11.35	13.06	18.65	40.80	26.56	46.39	-	-	-
2.0	7.52	15.90	16.23	22.66	61.63	27.73	70.50	-	-	-
2.5	8.74	19.48	21.53	37.93	78.30	64.89	92.96	-	-	-
3.0	10.92	20.85	31.51	49.94	93.27	103.45	118.13	150	109	125
3.5	12.52	21.54	43.33	61.56	115.67	142.84	137.86	230	129	148
4.0	16.81	35.64	59.78	98.05	176.22	180.70	140.78	300	148	171
4.5	27.99	56.39	88.91	138.35	229.09	235.18	155.16	370	170	208
5.0	41.13	71.26	102.20	157.86	264.37	302.83	218.04	450	207	264
5.5	48.27	82.26	118.78	171.53	295.90	349.95	305.13	535	254	326
6.0	53.53	93.14	134.45	201.14	321.68	398.94	367.70	620	302	386
6.5	54.21	101.89	150.46	229.62	339.38	451.81	412.42	690	352	449
7.0	59.66	107.92	164.24	246.41	359.75	504.36	470.32	750	404	515
7.5	64.80	-	178.10	-	379.97	547.39	530.14	815	471	590
8.0	70.65	-	188.06	-	407.04	561.53	601.35	890	556	680
8.5	-	-	-	-	-	590.88	669.96	-	-	-
9.0	-	-	-	-	-	632.76	725.97	970	784	894
9.5	-	-	-	-	-	663.03	795.40	-	-	-
10.0	-	-	-	-	-	690.38	843.75	1040	957	1140
10.5	-	-	-	-	-	-	897.44	-	-	-
11.0	-	-	-	-	-	-	948.39	1120	1100	1250
11.5	-	-	-	-	-	-	1004.88	-	-	-
12.0	-	-	-	-	-	-	1056.54	1200	1260	1400
13.0	-	-	-	-	-	-	-	1320	1420	1560
14.0	-	-	-	-	-	-	-	1370	1610	1730
15.0	-	-	-	-	-	-	-	1400	1760	1940
16.0	-	-	-	-	-	-	-	1450	1870	2140
17.0	-	-	-	-	-	-	-	-	1960	2280
18.0	-	-	-	-	-	-	-	-	2040	2410
19.0	-	-	-	-	-	-	-	-	2130	2530
20.0	-	-	-	-	-	-	-	-	2200	2630
21.0	-	-	-	-	-	-	-	-	-	2710
22.0	-	-	-	-	-	-	-	-	-	2780



Drawings, photos and data contained in this document are provided for information only. IVAL reserves the right to change them without notice.

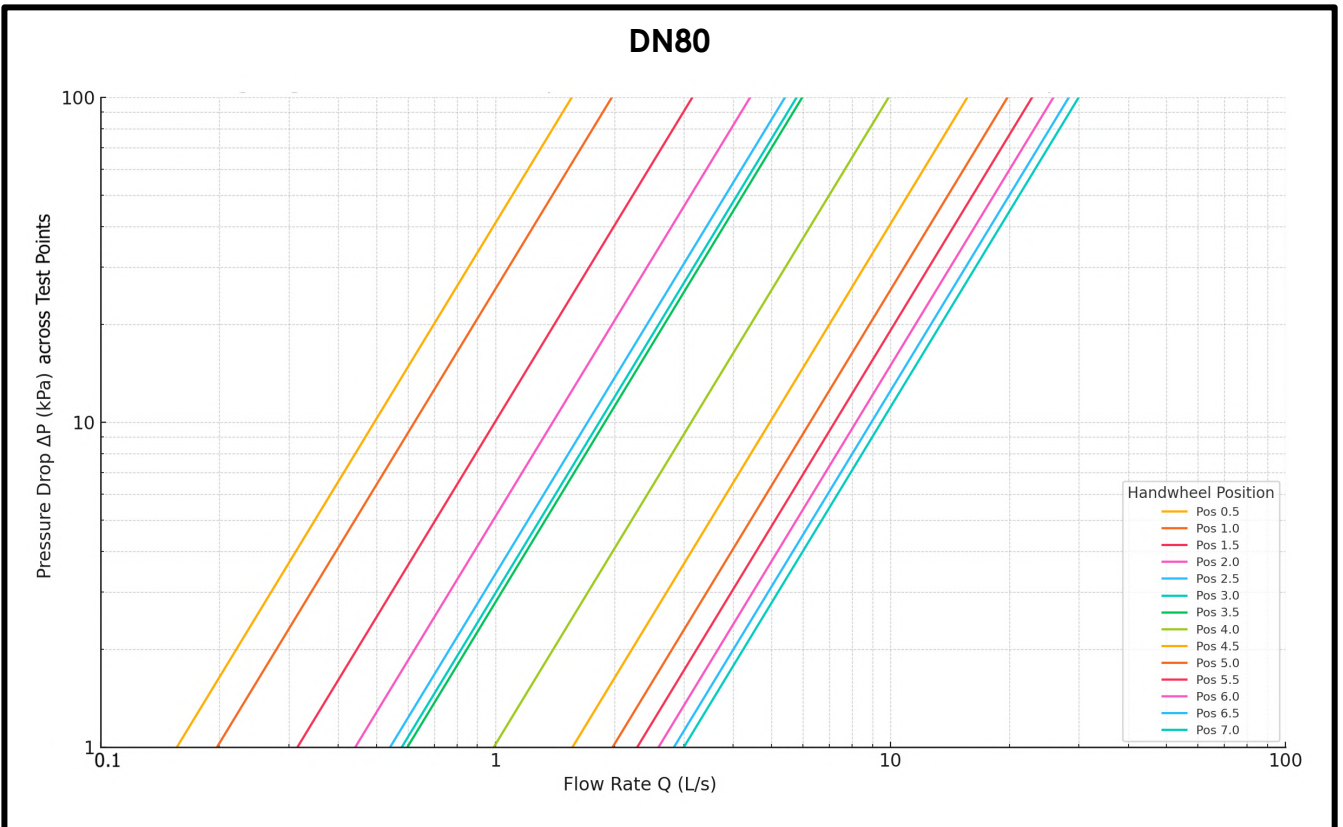
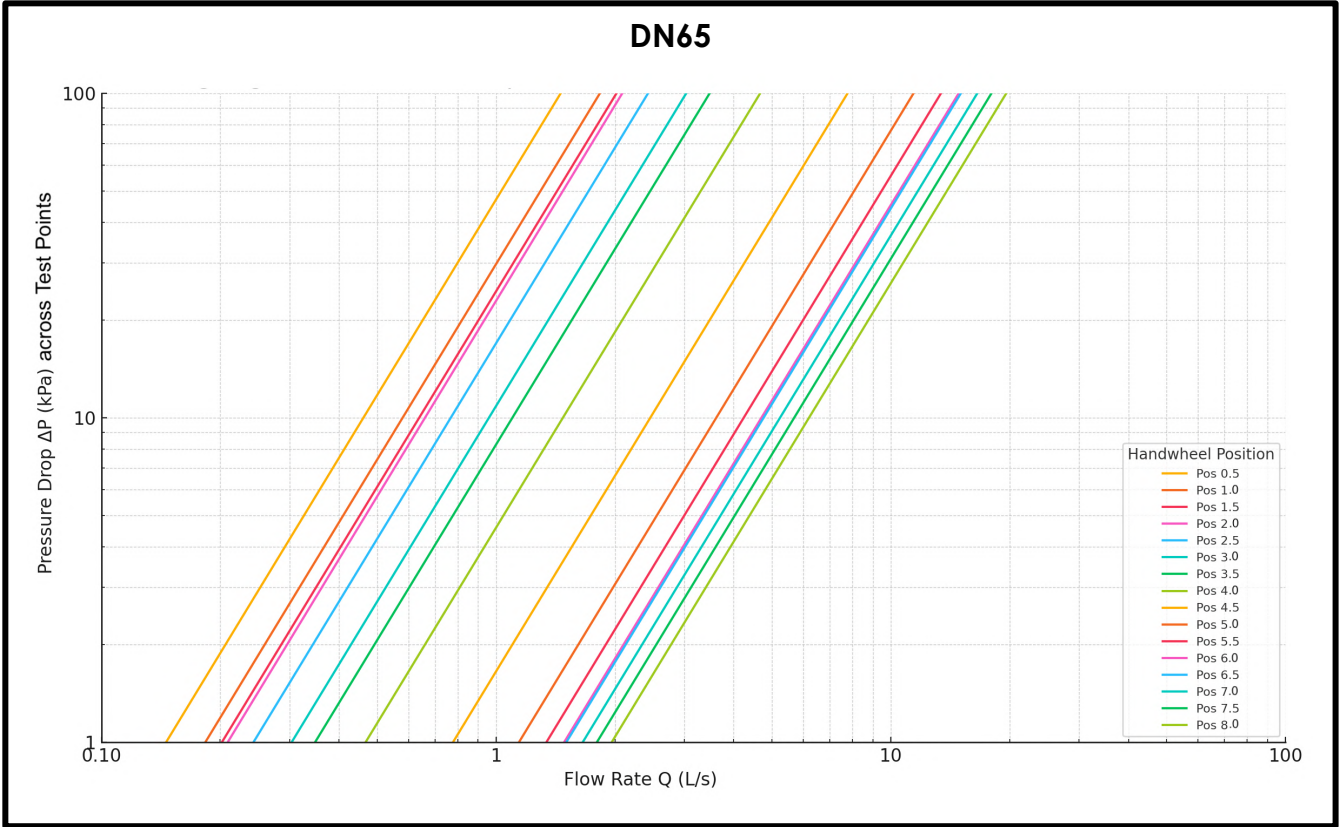

Drawings, photos and data contained in this document are provided for information only. IVAL reserves the right to change them without notice.

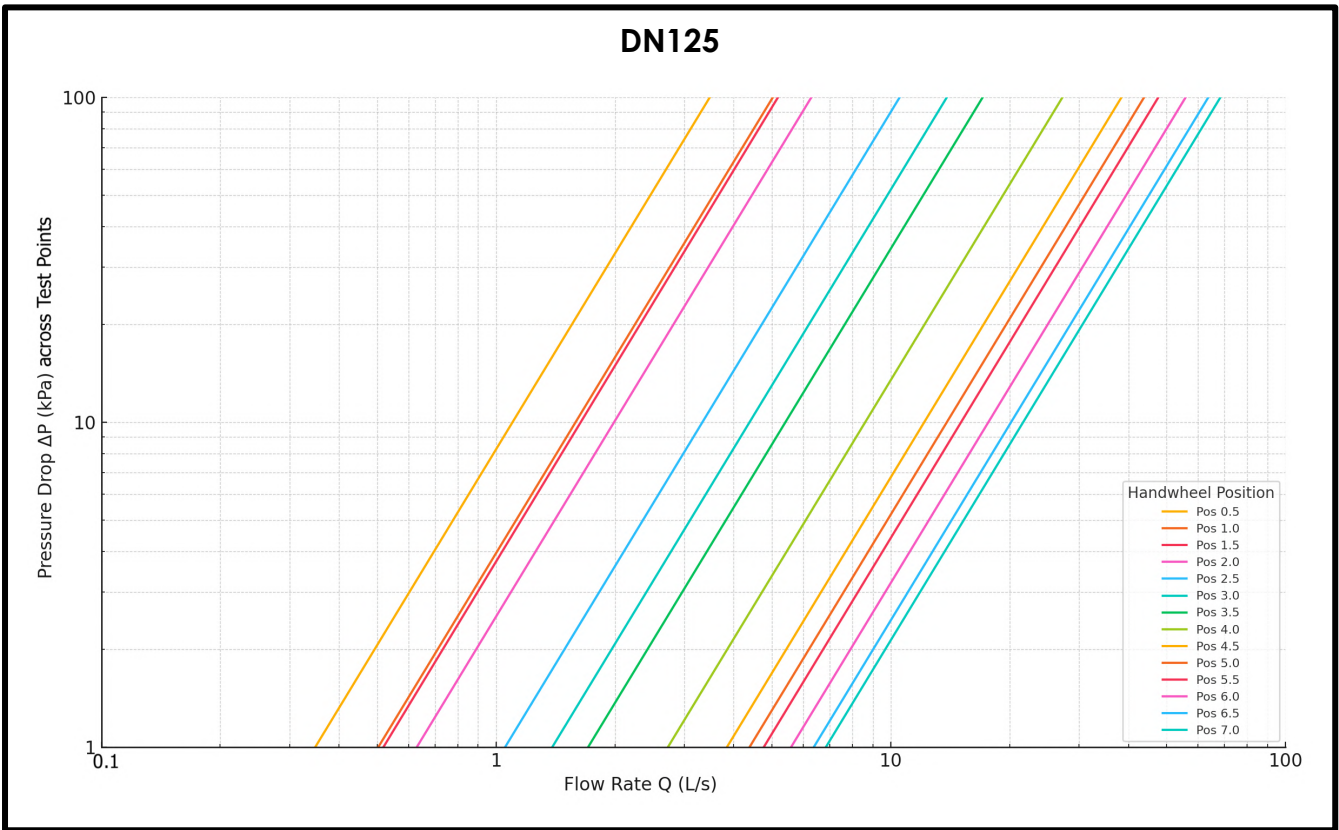
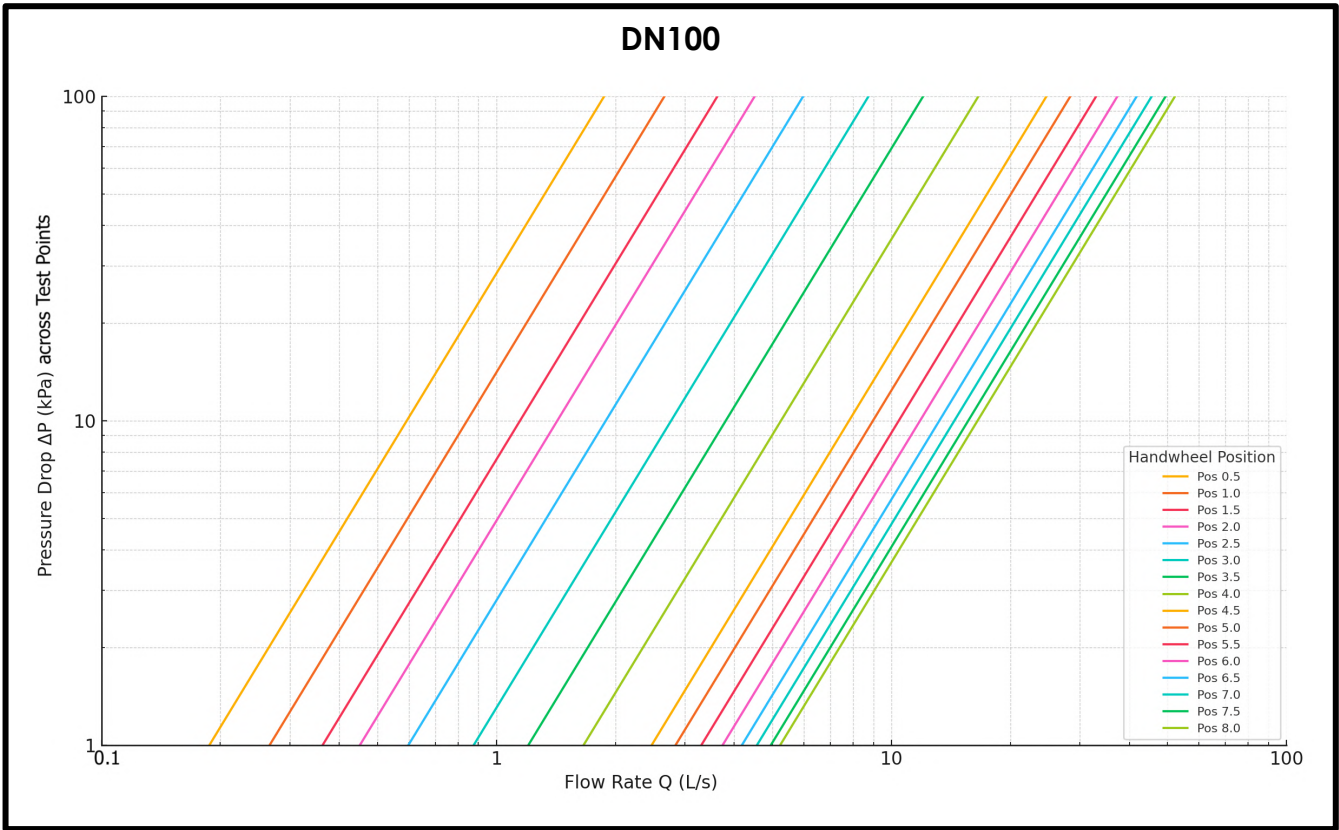

Email: info@ival-hydraulics.co.uk – Website: www.ival-hydraulics.co.uk



Drawings, photos and data contained in this document are provided for information only. IVAL reserves the right to change them without notice.

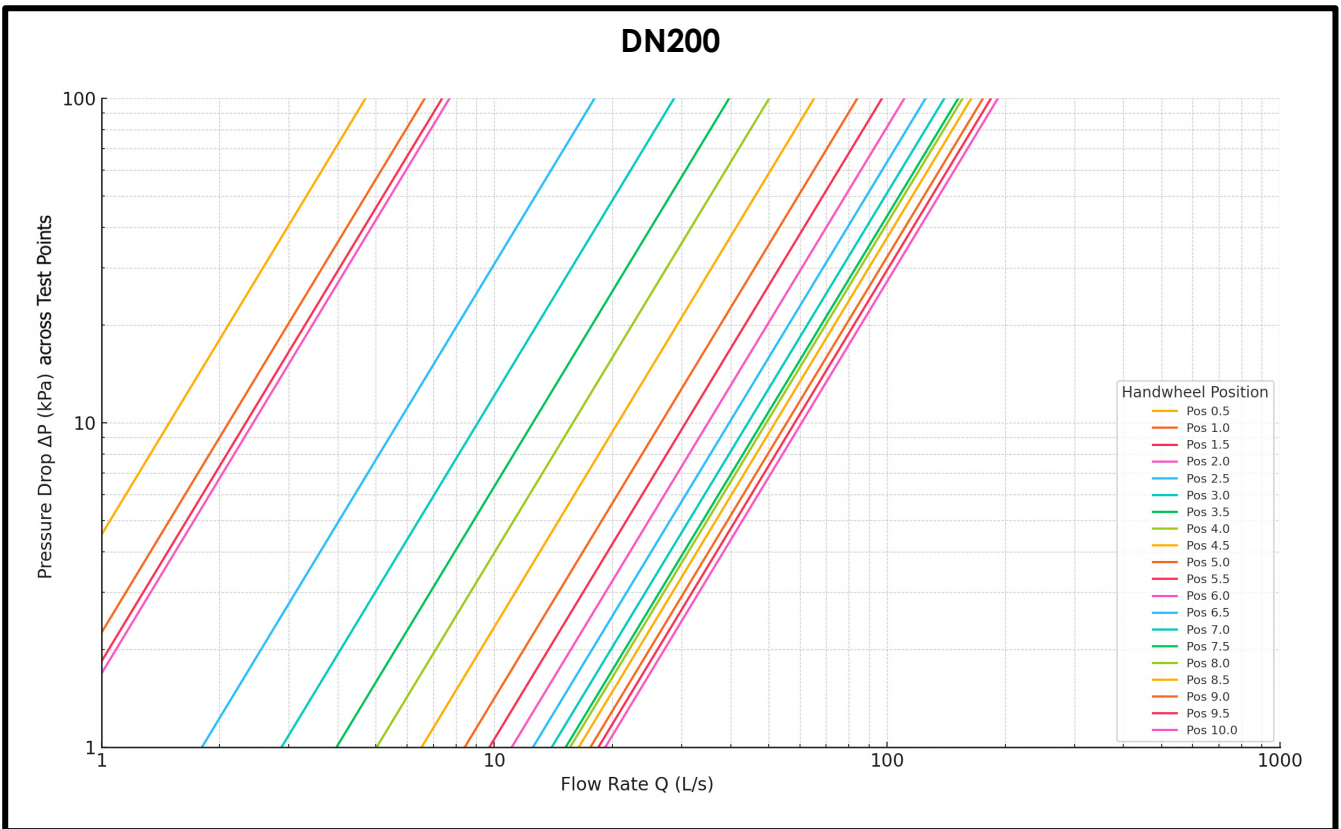
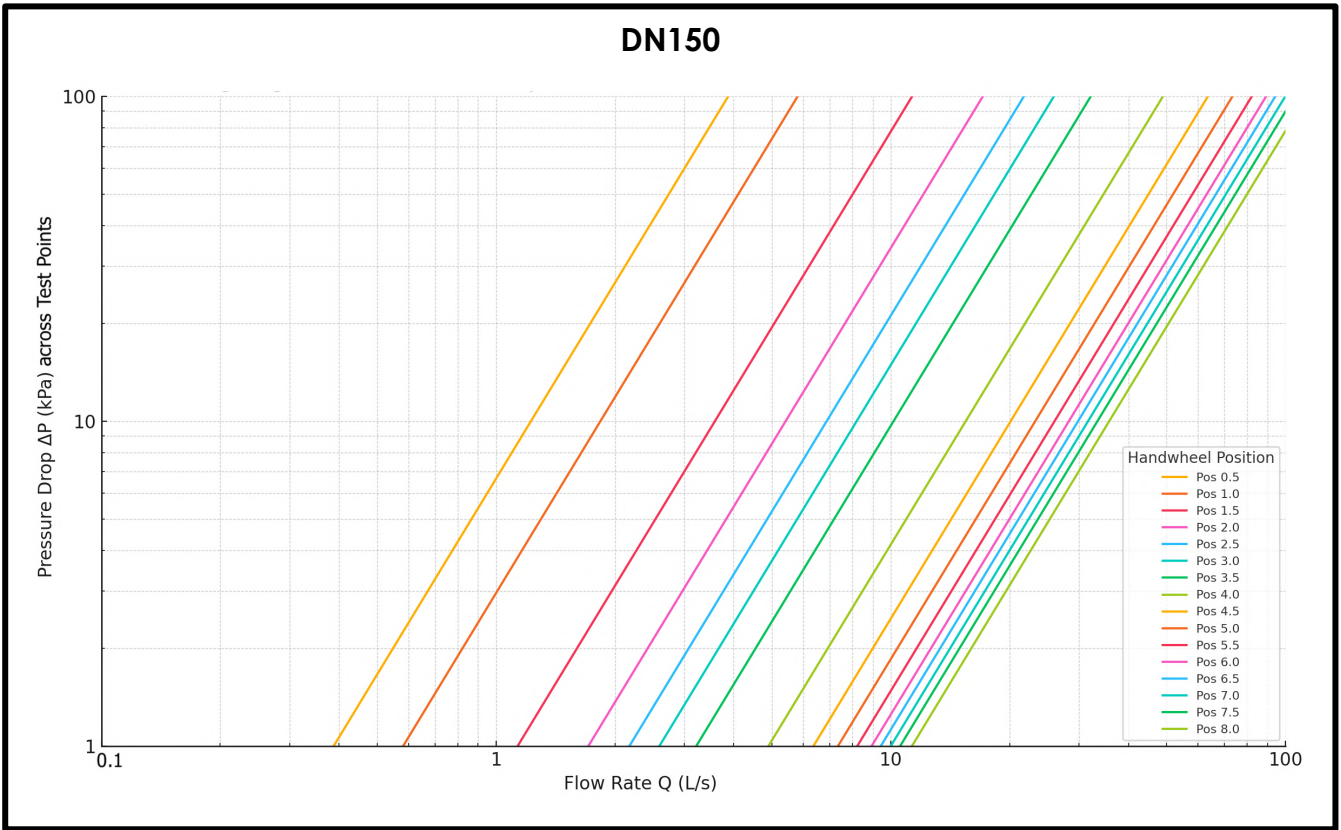

Drawings, photos and data contained in this document are provided for information only. IVAL reserves the right to change them without notice.

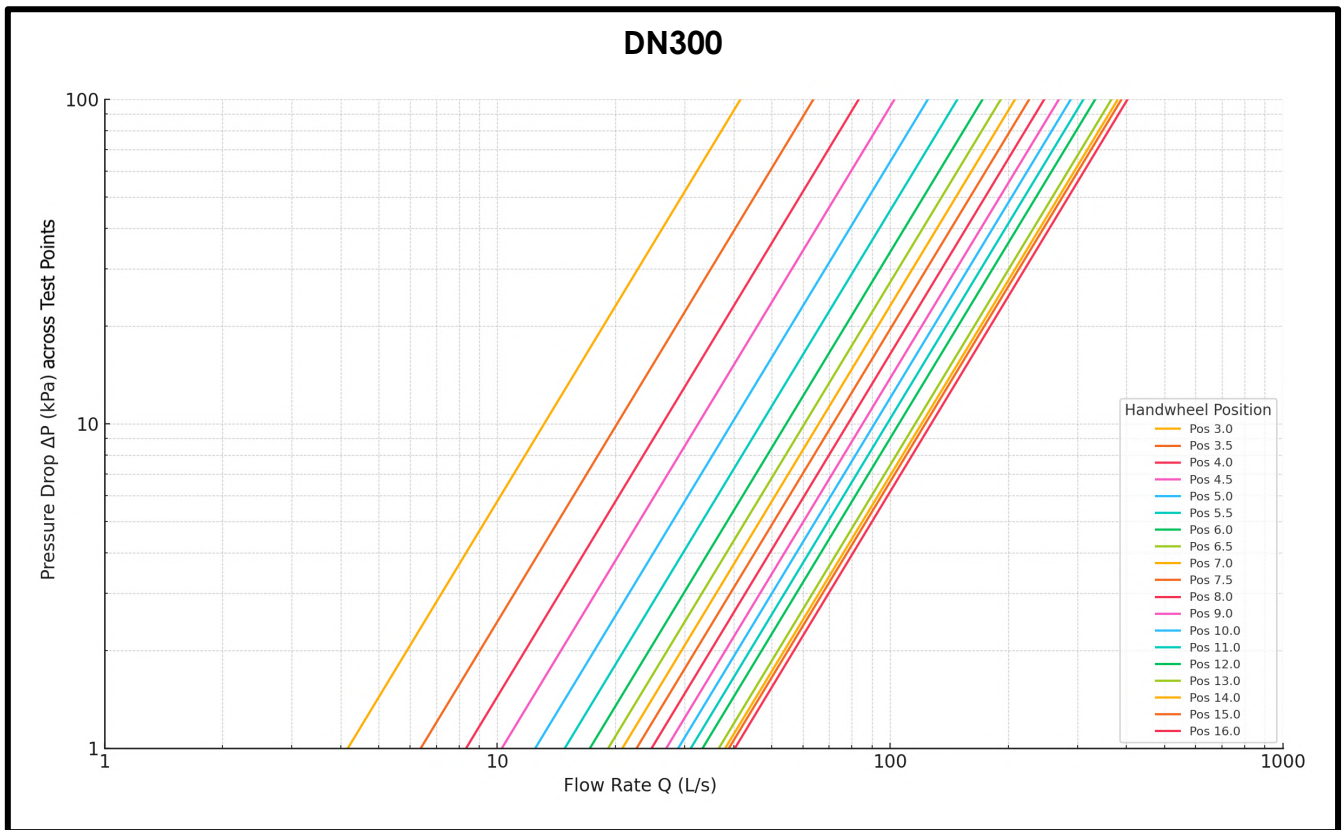
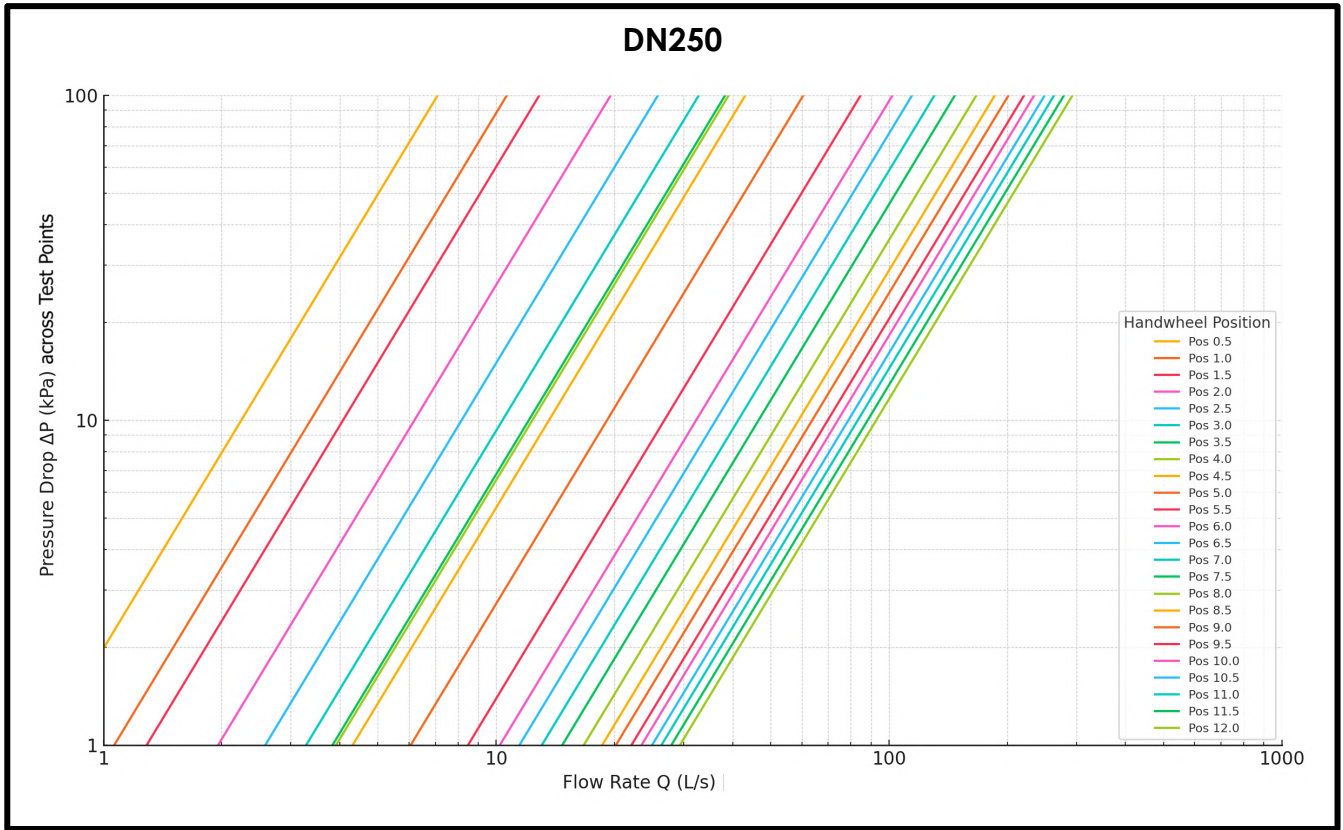

Drawings, photos and data contained in this document are provided for information only. IVAL reserves the right to change them without notice.

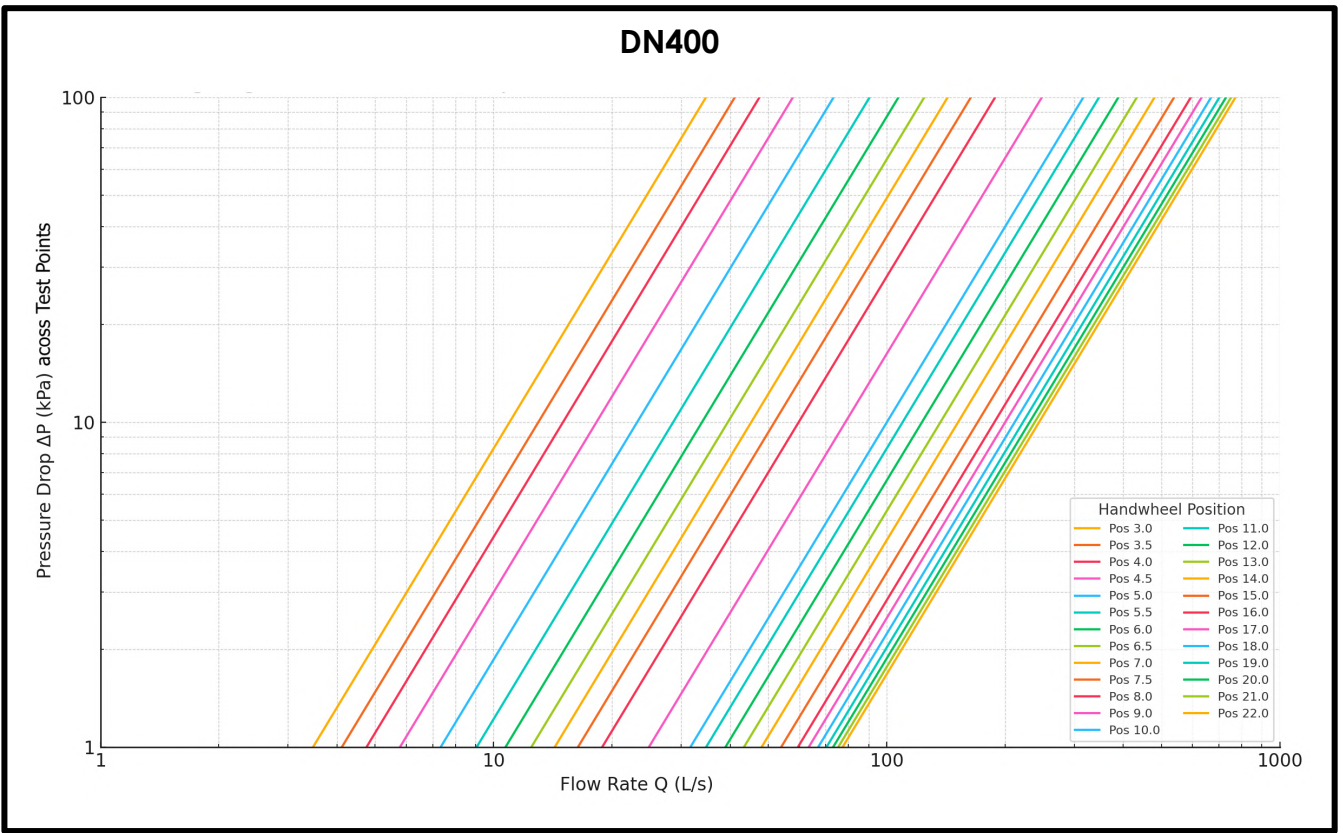
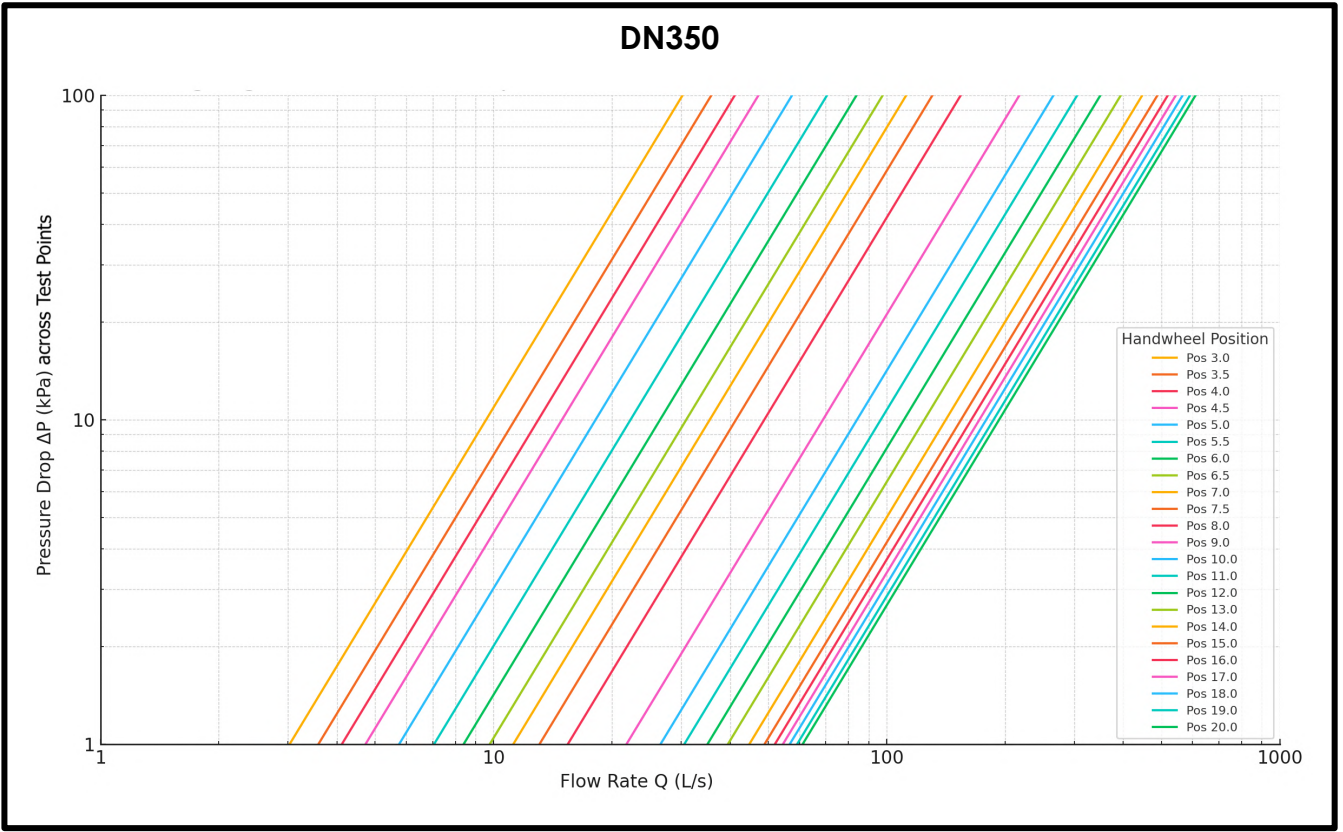

Email: info@ival-hydraulics.co.uk – Website: www.ival-hydraulics.co.uk



Headloss Calculations:

Formula linking flow **Q in (l/s)** and theoretical valve headloss **ΔP in (KPa)**.

Kv depends on handwheel position as indicated in table.

$$\Delta P = \left(\frac{36 \cdot Q}{K_v} \right)^2$$

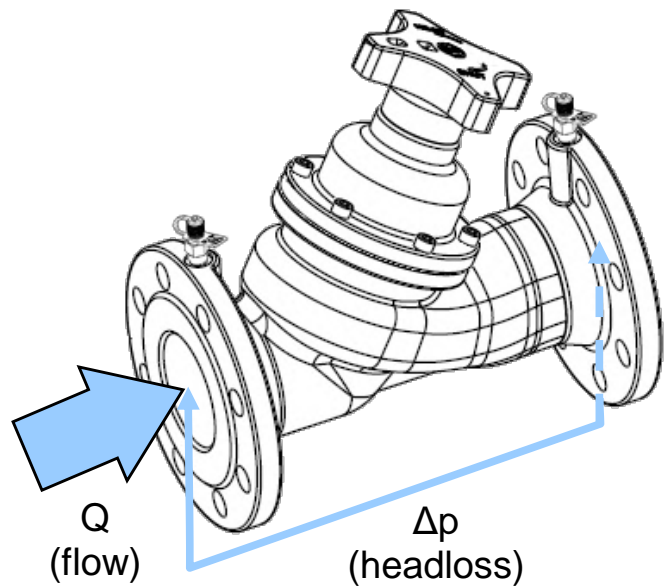
**Installation Instructions:**

For optimal performance, the Ductile Iron Double Regulating Valve (DRV) must be installed in accordance with the direction of flow indicated on the valve body. The valve should be in the fully closed position during installation to prevent damage to the internal sealing components caused by overtightening or debris.

It is essential to maintain straight, unobstructed pipe runs of at least **5 pipe diameters upstream** and **2 pipe diameters downstream** of the valve. This ensures a stable flow profile and accurate regulation, particularly when used in conjunction with flow measurement devices. Proper support and alignment of the connected piping must also be ensured to avoid mechanical stress on the valve body.

